

## T720 Series 6 and 8 foot Custom Identity Table with Lumber Top and Seats



**Model T720/CN-6UP** Custom Identity portable rectangular table, 6 ft. long with green powder coated frames and Untreated Pine top and seat planks.

Your custom message or logo included on end frames.

- **Custom identity laser cut into vertical frame supports.**
- **Nontip, nontrip, walk-through design**
- **All welded end frames are fabricated from 2-1/2" square steel tubing**
- **Diagonal braces align and strengthen entire table**
- **Frames are coated with durable powder coat finish in choice of colors**
- **Precision drilled, Untreated #1 Southern Yellow Pine Seat and Top Planks**

### SPECIFICATIONS:

- **Model T720** Tables include your custom identity on each vertical support panel.
- End frames are fabricated using 2-1/2" x 2-1/2" x 1/8" wall square tube for the base and seat supports; 10 ga. steel plate for the vertical support panel and the top/seat mounting angles. All welded fabrication. Table assembly includes two 1-5/16" OD steel tube diagonal braces.
- Each frame base includes (2) 9/16 in. dia. anchor bolt holes (*anchor bolts not included*).
- Frame design incorporates nontip, nontrip, walk-through design features.
- **Model T720/CB-6** has a nom. 6 ft. length.
- **Model T720/CB-8** has a nom. 8 ft. length.
- Nominal table height is 30". Nominal seat height is 18".
- **Custom Identity:** Each T720 Table includes your custom identity laser cut into the steel vertical support on each frame. Use this space for your agency name, school or team name, or other message (*design and space limitations apply*).
- **Standard:** All steel frame components are coated with black powder coat finish (indicated by "/CB" in model no., e.g. T720/CB-6UP). *See Specification Bulletin #SPC-CO-001.*
- **Standard:** Lumber is Untreated #1 grade Southern Yellow Pine (indicated by "UP" in model no., e.g. T720/CB-6UP) 2" x 10" nominal sized planks, kiln dried to reduce moisture content. All lumber is precision drilled for assembly and has all exposed edges removed to a 3/8" radius.
- All fasteners are provided for assembly.
- **Optional:** All steel frame components are hot-dip galvanized after fabrication to ASTM-A123 to maintain an average zinc coating of 2.0 oz. per sq. ft. of surface area
- **Optional:** Treated #1 Southern Yellow Pine is readily available and is pressure treated and kiln dried after treatment (KDAT) to preserve wood against decay. To specify, change "UP" in model no. to "TP", e.g. T720/CB-6TP. (*Cedar, Fir, and Redwood are available when in stock – please inquire.*)
- **Optional:** Surface mount anchor kit #ANC2-4. Use one kit per table.

### AVAILABLE OPTIONS

- 6' or 8' lengths
- Hot-dip galvanized finish on steel frame components
- Pressure treated #1 Southern Yellow Pine lumber (Cedar, Fir, or Redwood lumber when in stock)

## RJ Thomas Mfg. Co., Inc.

PO Box 946 • Cherokee, IA 51012-0946 • PH: 712-225-5115 • 800-762-5002 • FAX: 712-225-5796

E-mail: [customerservice@rjthomas.com](mailto:customerservice@rjthomas.com) • Web Site: <https://www.pilotrock.com>

© 2024 RJ Thomas Mfg. Co., Inc. PILOT ROCK® Park Products is a registered trademark of RJ Thomas Mfg. Co., Inc.

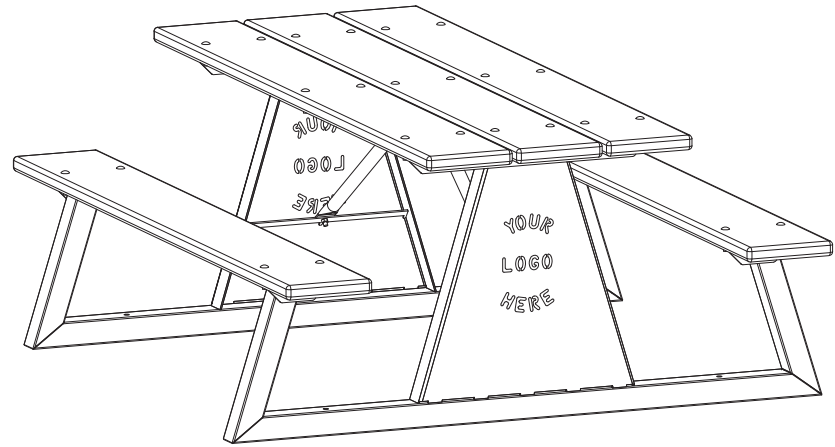
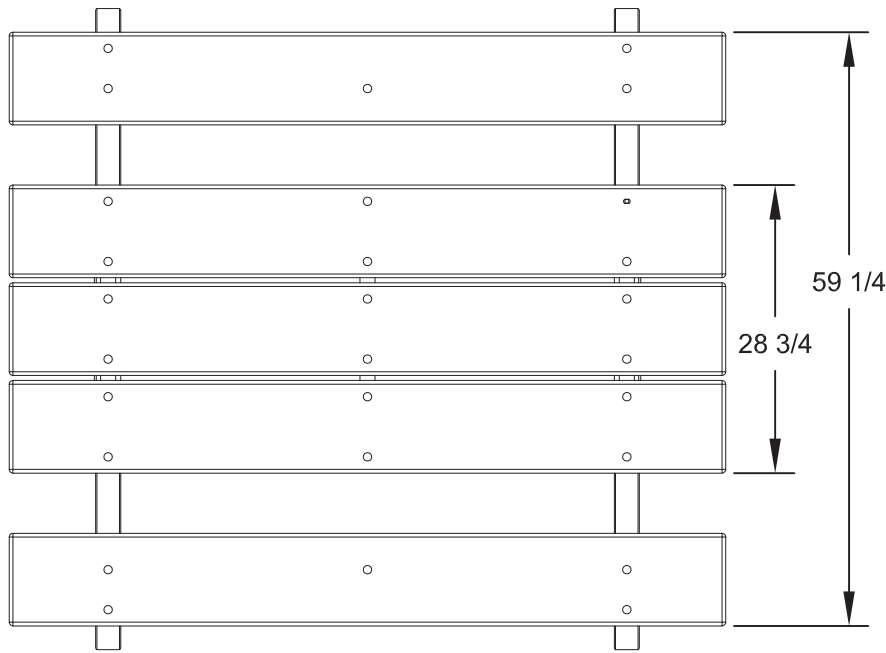

MODEL NUMBER	DIMENSION	
	a	b
T720-6	71 1/2	51 3/4
T720-8	95 1/2	70

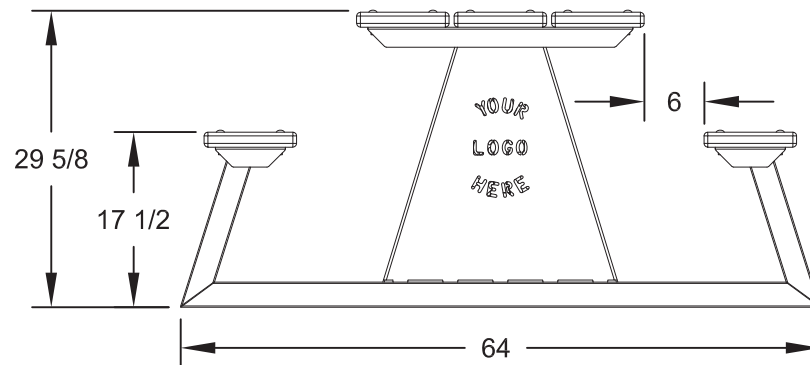
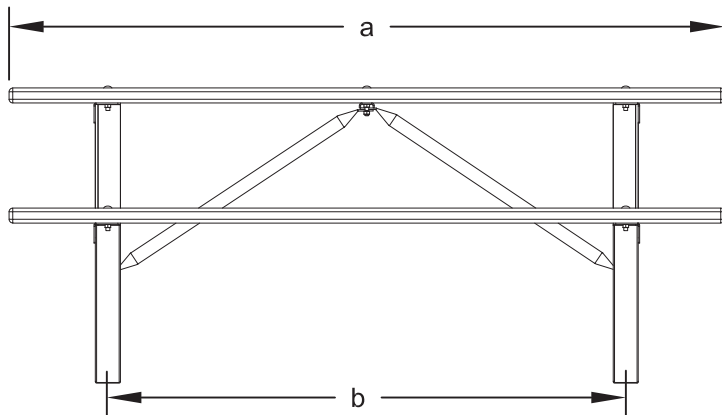

ALL DIMENSIONS IN INCHES

**RJThomas Mfg. Co., Inc.**  
P.O. Box 946 • Cherokee, IA 51012-0946

DRAWN BY  
**JGJ**

TITLE  
**T720 SERIES 6 AND 8 FOOT CUSTOM IDENTITY TABLE WITH LUMBER TOP AND SEAT PLANKS**

DATE 06-05-2024

DWG. NO. **AI-3059**