



Model T720/CB-8RO Custom Identity portable rectangular table, 8 ft. long with black powder coated frames and orange thermo-plastic coated R-type perforated steel top and seats.

Your custom message or logo included on end frames.

- **Custom identity laser cut into vertical frame supports.**
- **Nontip, nontrip, walk-through design**
- **All welded end frames are fabricated from 2-1/2" square steel tubing**
- **Diagonal braces align and strengthen entire table**
- **Frames are coated with durable powder coat finish in choice of colors**
- **Thermo-plastic Coating heat fused to Perforated Steel Top and Seats for durability**
- **Thermo-plastic Coating formulated with U.V. stabilizers for ultraviolet protection**

AVAILABLE OPTIONS

- **6' or 8' lengths**
- **Hot-dip galvanized finish on steel frame components**
- **Choice of colors of Thermo-plastic Coating**

SPECIFICATIONS:

- **Model T720** Tables include your custom identity on each vertical support panel.
- End frames are fabricated using 2-1/2" x 2-1/2" x 1/8" wall square tube for the base and seat supports; 10 ga. steel plate for the vertical support panel and the top/seat mounting angles. All welded fabrication. Table assembly includes two 1-5/16" OD steel tube diagonal braces.
- Each frame base includes (2) 9/16 in. dia. anchor bolt holes (*anchor bolts not included*).
- Frame design incorporates nontip, nontrip, walk-through design features.
- **Model T720/CB-6** has a nom. 6 ft. length.
- **Model T720/CB-8** has a nom. 8 ft. length.
- Nominal table height is 30". Nominal seat height is 18".
- **Custom Identity:** Each T720 Table includes your custom identity laser cut into the steel vertical support on each frame. Use this space for your agency name, school or team name, or other message (*design and space limitations apply*).
- **Standard:** All steel frame components are coated with black powder coat finish (indicated by "/CB" in model no., e.g. T720/CB-6RW). See Specification Bulletin #SPC-CO-001.
- **R-Type** table top (14 ga.) and seats (12 ga.) are each one-piece welded construction, fabricated from perforated steel, with 9/16" dia. holes in a 13/16" center to center in-line pattern, and 2" formed vertical edges on all sides and reinforced by a strap and angle substructure.
- **Standard:** All steel surfaces of the top and seats are covered with a thermo-plastic coating in a Brown color (indicated by "RW" in model no., e.g. T720/CB-6RW). The UV-stabilized thermo-plastic coating is applied in a multi step process of material preparation and finish application designed to permanently heat fuse and bond the finish to the steel. The thermo-plastic polyethylene finish is impact resistant, does not support mold or mildew, and the textured matte surface is less susceptible to marring and scuffing.
- All fasteners are provided for assembly.
- **Optional:** All steel frame components are hot-dip galvanized after fabrication to ASTM-A123 to maintain an average zinc coating of 2.0 oz. per sq. ft. of surface area.
- **Optional:** Color choices of Thermo-plastic coated steel components. For optional colors choices see Specification Bulletin #SPC-CO-001.
- **Optional:** Surface mount anchor kit #ANC2-4. Use one kit per table.

RJ Thomas Mfg. Co., Inc.

PO Box 946 • Cherokee, IA 51012-0946 • PH: 712-225-5115 • 800-762-5002 • FAX: 712-225-5796

E-mail: customerservice@rjthomas.com • Web Site: <https://www.pilotrock.com>

© 2024 RJ Thomas Mfg. Co., Inc. PILOT ROCK® Park Products is a registered trademark of RJ Thomas Mfg. Co., Inc.

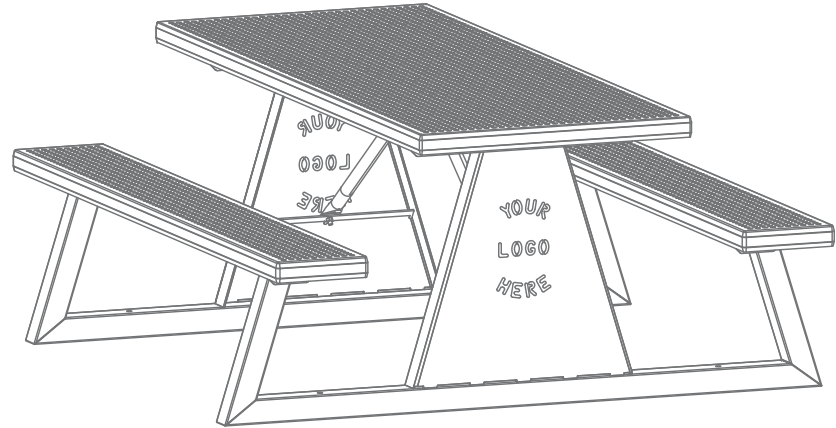
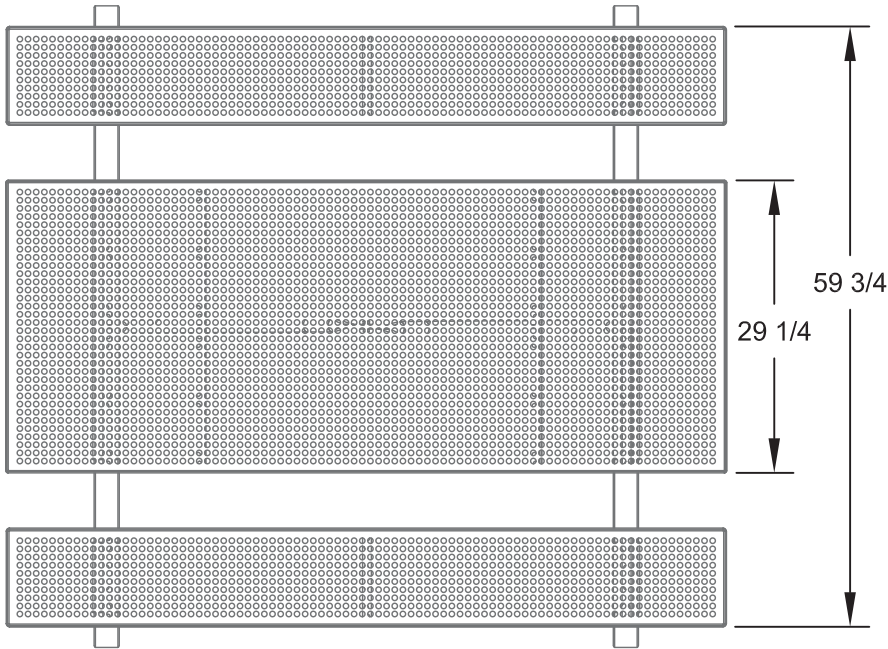

MODEL NUMBER	DIMENSION	
	a	b
T720-6	72	51 3/4
T720-8	96	70

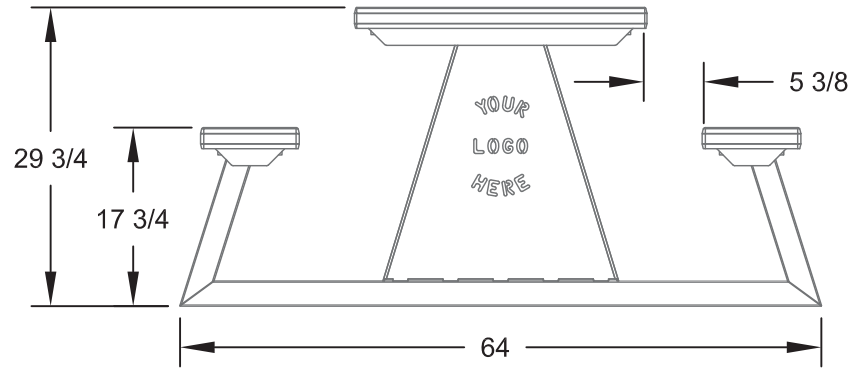
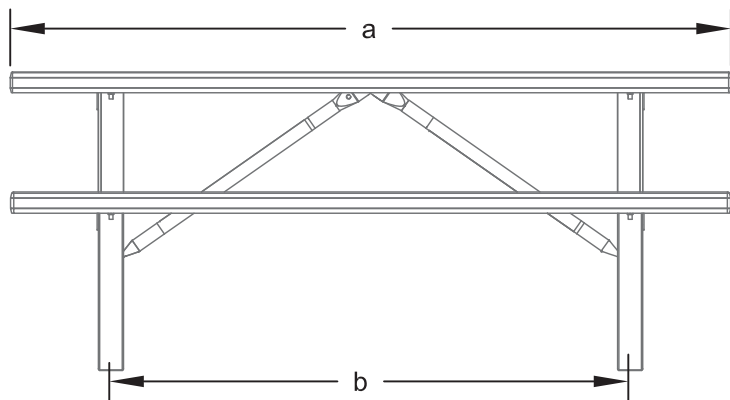

ALL DIMENSIONS IN INCHES

RJThomas Mfg. Co., Inc. P.O. Box 946 • Cherokee, IA 51012-0946	DRAWN BY JGJ	TITLE T720 SERIES 6 AND 8 FOOT CUSTOM IDENTITY TABLE WITH R-TYPE THERMO-PLASTIC COATED PERFORATED STEEL TOP AND SEAT PLANKS	DATE 06-07-2024
			DWG. NO. AI-3060