

T720 Series 6 and 8 foot Custom Identity Table with 100% Recycled Plastic Top and Seats



Model T720/CU-6PR Custom Identity portable rectangular table, 6 ft. long with blue powder coated frames and red 100% Recycled Plastic top and seat planks. Your custom message or logo included on end frames.

- **Custom identity laser cut into vertical frame supports.**
- **Nontip, nontrip, walk-through design**
- **All welded end frames are fabricated from 2-1/2" square steel tubing**
- **Diagonal braces align and strengthen entire table**
- **Frames are coated with durable powder coat finish in choice of colors**
- **100% Recycled Plastic Seat and Top Planks with solid color and U.V. stabilizer for ultraviolet protection**
- **Steel channel reinforcements under seats and table top**

SPECIFICATIONS:

- **Model T720** Tables include your custom identity on each vertical support panel.
- End frames are fabricated using 2-1/2" x 2-1/2" x 1/8" wall square tube for the base and seat supports; 10 ga. steel plate for the vertical support panel and the top/seat mounting angles. All welded fabrication. Table assembly includes two 1-5/16" OD steel tube diagonal braces.
- Each frame base includes (2) 9/16 in. dia. anchor bolt holes (*anchor bolts not included*).
- Frame design incorporates nontip, nontrip, walk-through design features.
- **Model T720/CB-6** has a nom. 6 ft. length.
- **Model T720/CB-8** has a nom. 8 ft. length.
- Nominal table height is 30". Nominal seat height is 18".
- **Custom Identity:** Each T720 Table includes your custom identity laser cut into the steel vertical support on each frame. Use this space for your agency name, school or team name, or other message (*design and space limitations apply*).
- **Standard:** All steel frame components are coated with black powder coat finish (indicated by "/CB" in model no., e.g. T720/CB-6PC). See Specification Bulletin #SPC-CO-001.
- **Standard:** Top and seats are made of 100% Recycled Plastic molded into 2" x 10" nominal sized planks with solid Cedar color (indicated by "PC" in model no., e.g. T720/CB-6PC) formed throughout and a U.V. stabilizer added for ultra-violet protection.
- Recycled Plastic table top and seat planks are supported by pregalvanized steel subframe channels.
- All fasteners are provided for assembly.
- **Optional:** All steel frame components are hot-dip galvanized after fabrication to ASTM-A123 to maintain an average zinc coating of 2.0 oz. per sq. ft. of surface area
- **Optional:** Color choices of Recycled Plastic components. See Specification Bulletin #SPC-CO-001.
- **Optional:** Surface mount anchor kit #ANC2-4. Use one kit per table.

AVAILABLE OPTIONS

- 6' or 8' lengths
- Hot-dip galvanized finish on steel frame components
- Choice of colors of Recycled Plastic

RJ Thomas Mfg. Co., Inc.

PO Box 946 • Cherokee, IA 51012-0946 • PH: 712-225-5115 • 800-762-5002 • FAX: 712-225-5796

E-mail: customerservice@rjthomas.com • Web Site: <https://www.pilotrock.com>

© 2024 RJ Thomas Mfg. Co., Inc. PILOT ROCK® Park Products is a registered trademark of RJ Thomas Mfg. Co., Inc.

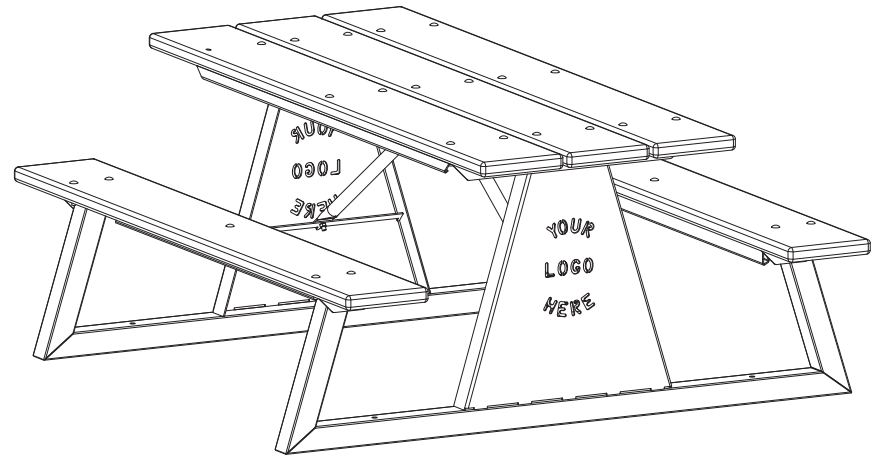
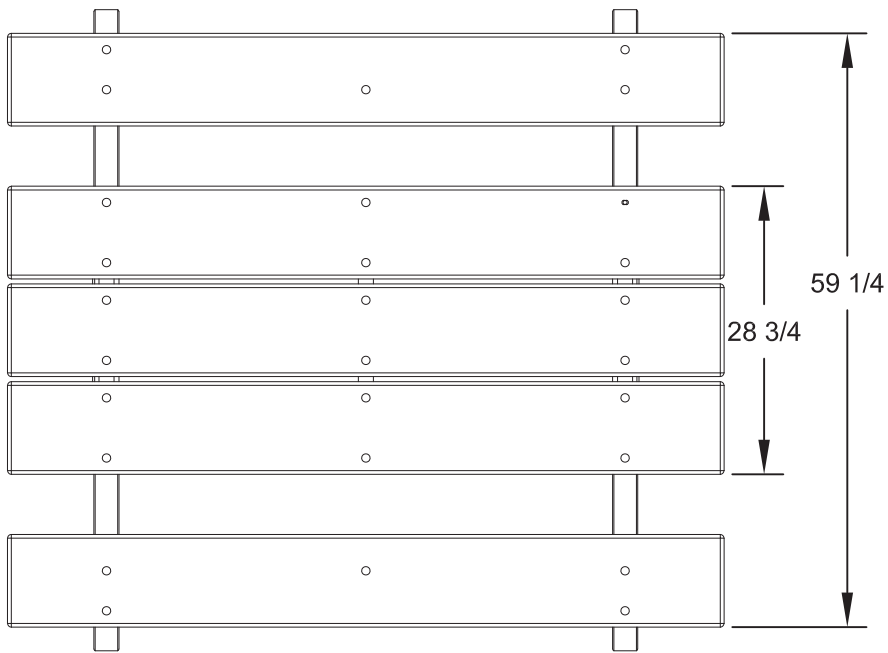

MODEL NUMBER	DIMENSION	
	a	b
T720-6	71 1/2	51 3/4
T720-8	95 1/2	70

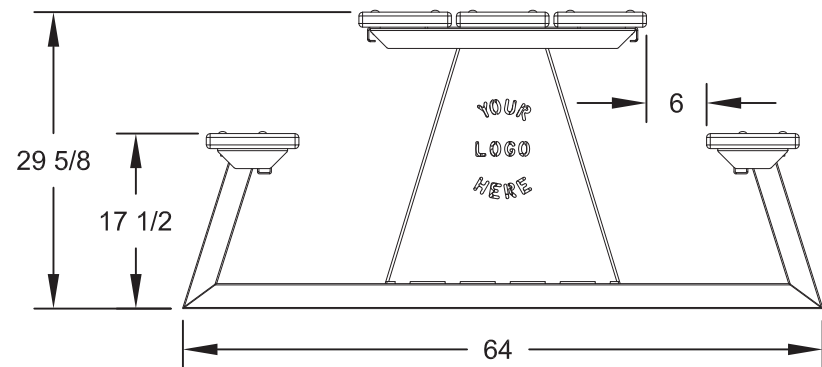
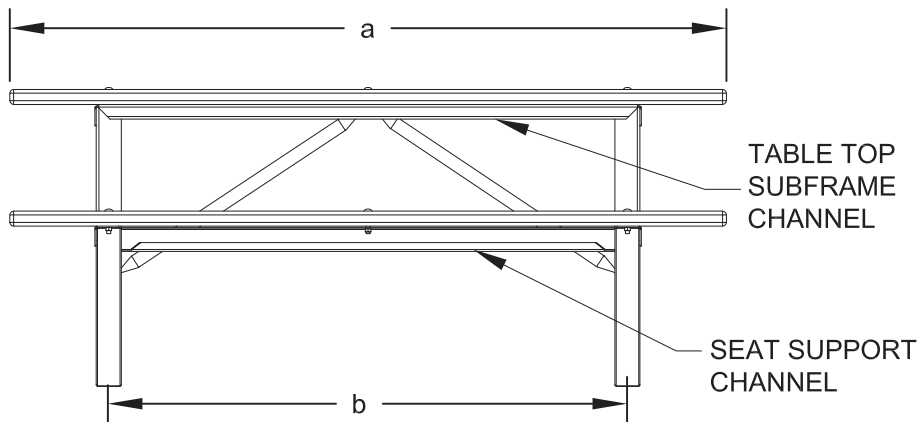

ALL DIMENSIONS IN INCHES

RJThomas Mfg. Co., Inc.
P.O. Box 946 • Cherokee, IA 51012-0946

DRAWN BY
JGJ

TITLE
T720 SERIES 6 AND 8 FOOT CUSTOM IDENTITY TABLE WITH 100% RECYCLED PLASTIC TOP AND SEAT PLANKS

DATE 06-05-2024

DWG. NO. **AI-3061**