

Model WXT/CB-8HU 8 Ft. Portable, Universal Rectangular Accessible Table with black powder coat frame and blue H-Type thermo-plastic coated perforated steel top and seats

- **Snow load/extreme load rated to 1420 lbs. per square foot**
- **Top and seats designed for more abusive environments such as high elevations where snow loads can destroy average tables**
- **Nontip, nontrip, walk-through design, wheelchair accessibility at each end**
- **Full capacity seating when wheelchairs are not in place**
- **All welded end frames are fabricated from 2-3/8" diameter steel pipe**
- **Diagonal braces align and strengthen entire table**
- **Frames are hot dip galvanized after fabrication for superior corrosion resistance**
- **Thermo-plastic Coating heat fused to Perforated Steel Top and Seats for durability**
- **Thermo-plastic Coating formulated with U.V. stabilizers for ultraviolet protection**
- **Limited Lifetime Warranty on frames**

AVAILABLE OPTIONS

- **6' or 8' lengths**
- **Powder Coat Finish in choice of colors on steel frame components**
- **Choice of colors of Thermo-plastic Coating**

SPECIFICATIONS:

- **WXT Series** end frames are one-piece welded construction, fabricated from 2.375" (2-3/8") O.D. x 10 ga. wall steel pipe to meet 2" nominal steel pipe size specifications with 2" x 2" x 1/8" die-formed steel angle for attaching seats and top. Bends are tightly formed to prevent tipping when weight is on one side.
- Frame design provides the ADA recommended wheelchair clearances under the table top of: 30" wide, 27" high and 24" total knee and toe clearance (19" knee + 5" toe) at each end of the table while maintaining full seating capacity of the table.
- **Snow Load Capacity:** This table has been independently tested to meet the U.S. Forest Service snow load requirement of 1420 lbs. per square foot. (Test results available upon request)
- Frame design incorporates nontip, nontrip, walk-through features.
- **Model WXT/G-6** is a nom. 6 ft. in length.
- **Model WXT/G-8** is a nom. 8 ft. in length.
- Nominal table height is 30". Frame design provides a nominal 28" of clearance from ground level to the underside of table. Nominal seat height is 18".
- Frames are supported by diagonal braces of 1-5/16" O.D. x 14 ga. wall steel pipe connected to the table top.
- All fasteners are provided for assembly.
- **Standard:** All steel frame components are hot-dip galvanized after fabrication to ASTM-A123 to maintain an average zinc coating of 2.0 oz. per sq. ft. of surface area (indicated by "/G" in model no., e.g. WXT/G-6HW).
- **H-Type** table top and seats are each a one-piece welded construction, fabricated from a 14 ga. perforated steel surface with 9/16" dia. holes in a 13/16" center to center in-line pattern and 2-1/2" x 10 ga. roll-formed vertical edges on all sides reinforced by a 10 ga. die-formed angle substructure. Substructure includes all mounting holes for easy assembly of table.
- **H-Type** perforated steel is designed and constructed specifically to withstand high elevation snow and other extreme loads and for heavy use areas where unusually difficult service may be required.
- **Standard:** All steel surfaces of the top and seats are covered with a thermo-plastic coating in a Brown color (indicated by "HW" in model no., e.g. WXT/G-6HW). The UV-stabilized thermo-plastic coating is applied in a multi step process of material preparation and finish application designed to permanently heat fuse and bond the finish to the steel. The thermo-plastic polyethylene finish is impact resistant, does not support mold or mildew, and the textured matte surface is less susceptible to marring and scuffing.
- **Optional:** All steel frame components have powder coat finish. See Specification Bulletin #SPC-CO-001.
- **Optional:** Color choices of Thermo-plastic coated steel components. For optional colors choices see Specification Bulletin #SPC-CO-001.
- **U.S. Patent Nos. D489,539; D490,992; D493,291; D496,799; D497,262; 6,918,630**

RJ Thomas Mfg. Co., Inc.

PO Box 946 • Cherokee, IA 51012-0946 • PH: 712-225-5115 • 800-762-5002 • FAX: 712-225-5796

E-mail: customerservice@rjthomas.com • Web Site: <https://www.pilotrock.com>

© 2025 RJ Thomas Mfg. Co., Inc. PILOT ROCK® Park Products is a registered trademark of RJ Thomas Mfg. Co., Inc.

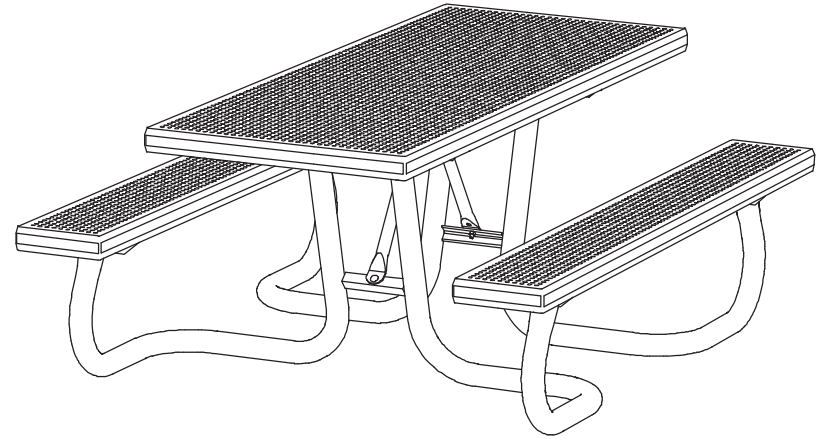
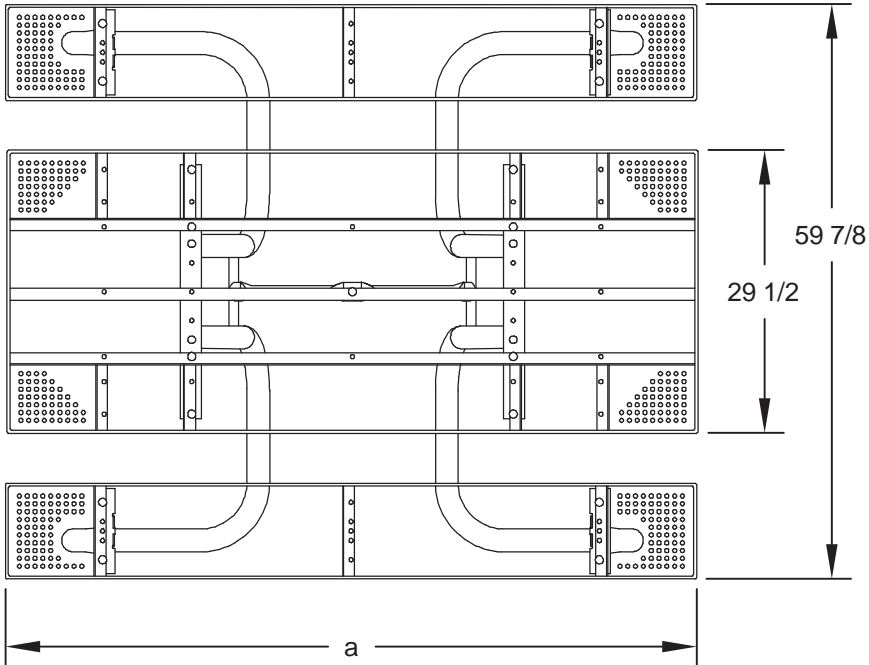

MODEL NUMBER	DIMENSION	
	a	b
WXT-6	72	19-5/8
WXT-8	96	37-7/8

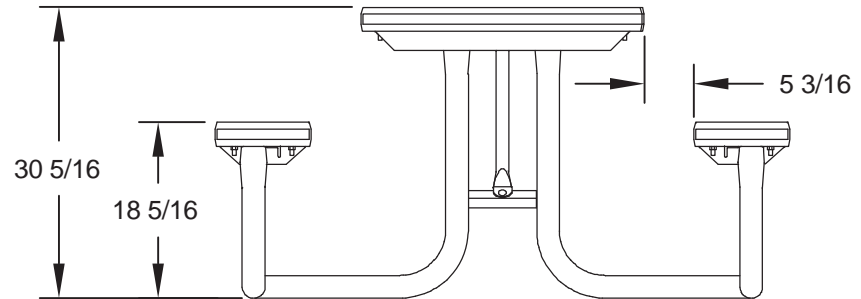
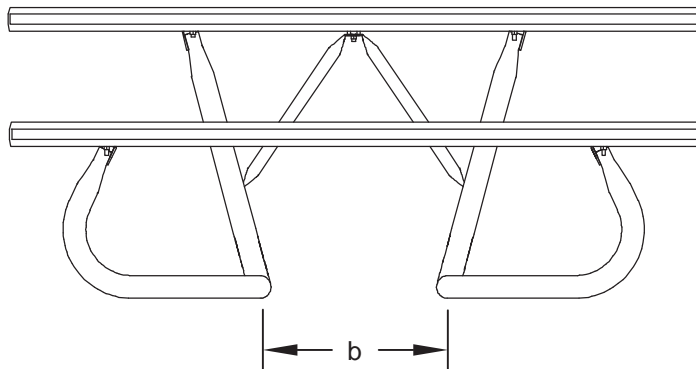

ALL DIMENSIONS IN INCHES

RJThomas Mfg. Co., Inc.
P.O. Box 946 • Cherokee, IA 51012-0946

DRAWN BY
WWM

TITLE **MODEL WXT SERIES 6 AND 8 FOOT UNIVERSAL ACCESS TABLES
WITH H-TYPE THERMO-PLASTIC COATED PERFORATED
STEEL TOP AND SEATS**

DATE 3-17-10

DWG. NO. **AI-1633**